



# Cactus Flower

*By Alex Anderson; quilted by Angela Walters*

*Quilt size 65¼" x 65¼"; Block size: 8"*

*Featuring Chirp by Alex Anderson for RJR Fabrics*



# Cactus Flower yardage



#quiltwithlove

	color	sku	yards
	Gray sprig print	2646-03	1 <sup>3</sup> / <sub>4</sub> yds.
	White on white print	2643-03	2 <sup>1</sup> / <sub>2</sub> yds.
	Gray flower print	2644-03	1 <sup>1</sup> / <sub>4</sub> yd.
	Gray bird print	2641-03	5/8 yd.
	Gray leaf print	2642-03	1/2 yd.
	White floret/gray	2645-04	1/2 yd.
	Blue/Aqua prints	2640-01	
		2641-01	
		2642-01	
		2643-01	
		2644-01	
		2645-01	
		2645-02	
		2646-01	
		2646-04	9 total 1/4-yd. cuts
		Gray prints	2640-02
	2640-03		
	2642-03		
	2646-05		4 total fat 1/8
	Yellow prints	2641-02	
		2642-02	
		2643-02	
		2644-02	
		2645-03	
		2646-02	6 total fat 1/8

# Cactus Flower instructions

Quilt size 65<sup>1</sup>/<sub>4</sub>" x 65<sup>1</sup>/<sub>4</sub>"

Block size 8" x 8"

## Fabric & Cutting Requirements

Gray sprig print (2646-03)	1 <sup>3</sup> / <sub>4</sub> yds.	4 border strips 7 <sup>1</sup> / <sub>2</sub> " x 58 <sup>3</sup> / <sub>4</sub> "
White on white print (2643-03)	2 <sup>1</sup> / <sub>2</sub> yds.	4 border strips 3 <sup>1</sup> / <sub>2</sub> " x 48 <sup>3</sup> / <sub>4</sub> " 2 strips 3 <sup>1</sup> / <sub>2</sub> " x 40" 2 strips 3" x 40" 32 A, 16 B, 8 C, 32 D
Gray flower print (2644-03)	1 <sup>1</sup> / <sub>4</sub> yd.	1 strip 3 <sup>1</sup> / <sub>2</sub> " x 40" 4 strips 3" x 40" 8 binding strips 2 <sup>1</sup> / <sub>4</sub> " x 40"
Gray bird print (2641-03)	<sup>5</sup> / <sub>8</sub> yd.	3 E, 2 F
Gray leaf print (2642-03)	<sup>1</sup> / <sub>2</sub> yd.	8 flange strips 1" x 40"
White floret/gray (2645-04)	<sup>1</sup> / <sub>2</sub> yd.	bias strip <sup>1</sup> / <sub>2</sub> " x 280"
Blue/Aqua prints 2640-01, 2641-01, 2642-01, 2643-01, 2644-01, 2645-01, 2645-02, 2646-01, 2646-04	9 total <sup>1</sup> / <sub>4</sub> -yd. cuts	48 A, 16 C, 24 flowers**
Gray prints 2640-02, 2640-03, 2642-03, 2646-05	4 total fat <sup>1</sup> / <sub>8</sub>	48 leaves, 12 circles**
Yellow prints 2641-02, 2642-02, 2643-02, 2644-02, 2645-03, 2646-02	6 total fat <sup>1</sup> / <sub>8</sub>	24 flower centers**
Backing*	4 <sup>1</sup> / <sub>2</sub> yds.	2 panels 37 <sup>1</sup> / <sub>2</sub> " x 74"
Batting*	74" x 74"	

Yardage is based on fabric 40" wide. Cut border strips and white print strips lengthwise, parallel to the selvedge. Border strips are exact length including seam allowances. Yardage is estimated for fusible, raw-edge machine applique. If you prefer turned-edge applique, increase fabric amounts accordingly.

You may have a little extra fabric with this kit. The more prints you have, the scrappier your quilt will be! Add the scraps to your stash, or perhaps a coordinating pillow might be the ticket for your Cactus Flower quilt.

\*not included in kit

\*\*wait to cut these patches as you need them

Also needed: 2 yards 20"-wide fusible web; thread to match applique patches

## Patches

A = 2<sup>7</sup>/<sub>8</sub>" x 2<sup>7</sup>/<sub>8</sub>" square

B = 2<sup>1</sup>/<sub>2</sub>" x 2<sup>1</sup>/<sub>2</sub>" square

C = 4<sup>7</sup>/<sub>8</sub>" x 4<sup>7</sup>/<sub>8</sub>" square

D = 2<sup>1</sup>/<sub>2</sub>" x 4<sup>1</sup>/<sub>2</sub>" rectangle

E = 13" x 13" square

F = 6<sup>3</sup>/<sub>4</sub>" x 6<sup>3</sup>/<sub>4</sub>" square

## Before you start

Read through the assembly instructions before beginning.

Soak all dark and bright fabrics in hot water to release any excess dye. Better safe than sorry!

When sewing half-square triangle units for this pattern, accuracy is very important. Sew a test block and be sure your seams measure exactly <sup>1</sup>/<sub>4</sub>". Presser feet can vary, so you may wish to mark the throat plate of your machine with tape as a guide for sewing a precise <sup>1</sup>/<sub>4</sub>" seam. For accuracy and ease of handling, starch your fabric firmly before cutting.

## Cutting

Refer to the Fabric and Cutting Requirements. Cut the border strips and white print strips lengthwise, parallel to the selvedge. Cut the gray flower flange strips and binding strips crosswise.

Cut a 13" x 13" square from the white floret/gray print and set it aside to make bias strips later. Wait to cut the remaining fabric until you make the basket blocks and complete the applique.

Cut E's and F's from the gray bird print. Cut the white on white A's, B's, C's, and D's. Cut these C's in half diagonally. Set these patches aside for Cactus Basket blocks. Cut the flange and binding strips and set them aside.

## Making the Cactus Basket blocks

Refer to the quilt photo and note the scrappy effect Alex created for the baskets. Each basket block is made from 3 different prints plus white on white print. Alex found it convenient to work from  $2\frac{7}{8}$ " and  $4\frac{7}{8}$ " strips cut from the blue and aqua fabrics. She also added a few patches cut from yellow prints and gray prints. Combine fabrics as Alex did, or as desired.

Cut the patches for each basket as you need them. Start by making half-square triangle units for the "points." Cut 2 A's from a blue or aqua print strip. Referring to Fig. 1, place a blue A right sides together with a white on white A. Draw a diagonal line, corner to corner, on the back of the white on white A. Stitch  $\frac{1}{4}$ " away from both sides of the drawn line. Cut on the line and press the triangles open. Repeat to make 4 half-square triangle units.

Choose a contrasting fabric for the inside of the basket. Cut a C. Cut the C in half diagonally and set one triangle aside for use in another basket.

Choose a third fabric for the basket base. Cut 1 A and 1 C. Cut the patches in half diagonally. Set one C triangle aside for use in another basket.

Refer to the Cactus Basket piecing diagram. On a design wall or flat surface, arrange the patches with 1 white on white B, 1 white on white C, and 2 white on white D's as shown. Join the patches. Press the block. It should measure exactly  $8\frac{1}{2}$ " x  $8\frac{1}{2}$ " raw edge to raw edge.

Make 16 Cactus Basket blocks. Set aside remaining fabric for the appliqued flowers.

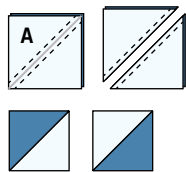
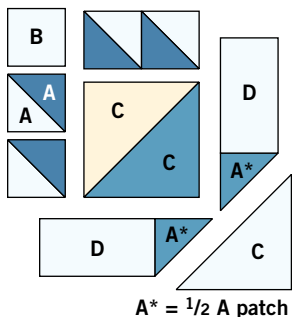

Fig. 1



**Cactus Basket Piecing**  
Make 16

## Making the Uneven Nine-Patch blocks

Refer to the Band 1 diagram. Sew one  $3\frac{1}{2}$ " white on white strips between 2 gray flower print 3" strips. Press the seam allowances toward the gray strips. Make sure your seams are accurate and the band measures  $8\frac{1}{2}$ " wide. Make 2 Band 1. Cut a total of 18 Band 1 segments, each 3" wide.

Refer to the Band 2 diagram. Sew one  $3\frac{1}{2}$ " gray flower print strip between two 3" white on white strips. Press the seam allowances toward the gray strip. Again check the width of the band for accuracy. Cut a total of 9 Band 2 segments, each  $3\frac{1}{2}$ " wide.

Refer to the Uneven Nine-Patch piecing diagram. Sew a Band 2 segment between 2 Band 1 segments. Press the block. It should measure exactly  $8\frac{1}{2}$ " x  $8\frac{1}{2}$ " raw edge to raw edge. Make 9 Uneven Nine Patch blocks.

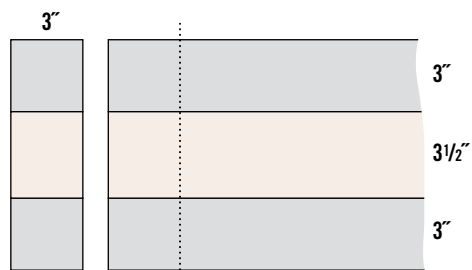

**Band 1**  
Make 2

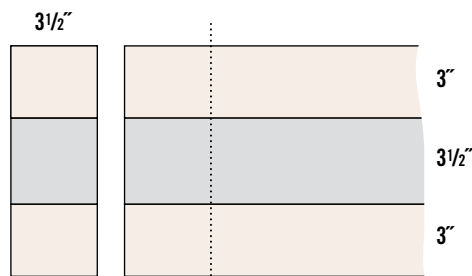

**Band 2**  
Make 1

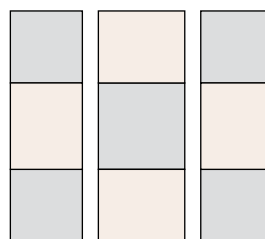

**Uneven Nine-Patch Piecing**  
Make 9

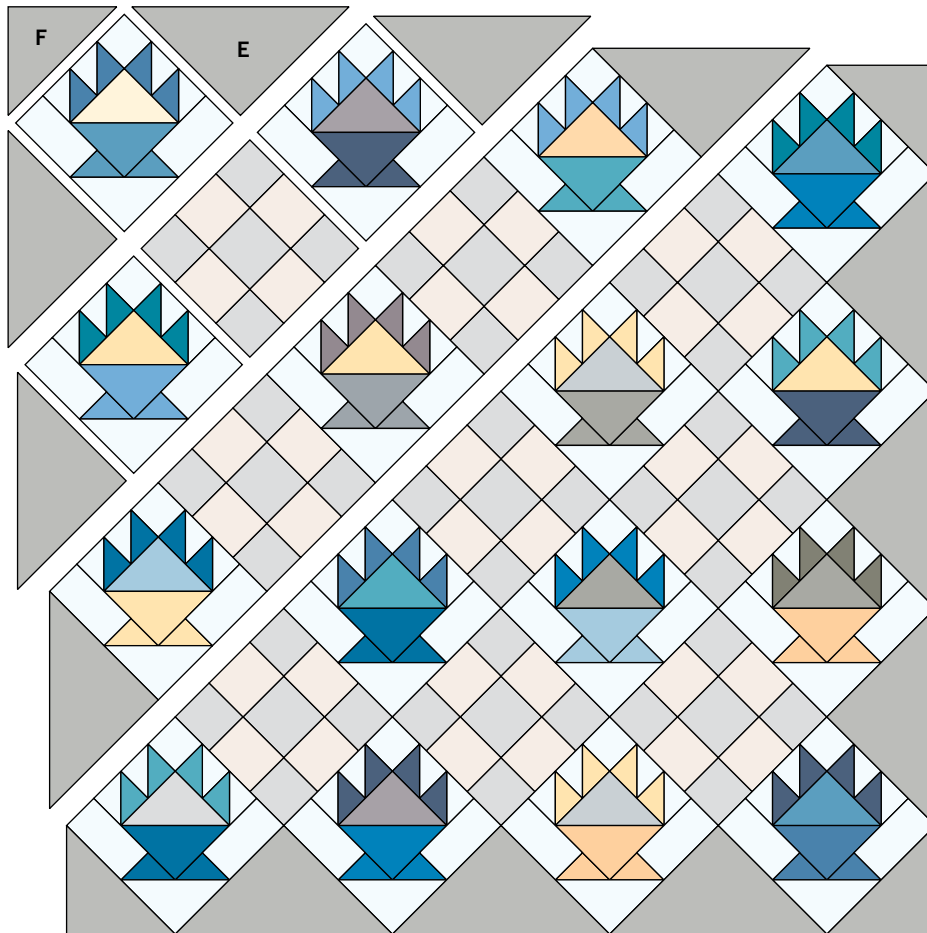

**Quilt Center Assembly**

## Assembling the quilt center

Cut a gray bird print E diagonally twice to make 4 quarter-square triangles. Repeat to make 12 triangles.

Refer to the quilt center assembly diagram. On a design wall or large flat surface, arrange the blocks in diagonal rows, alternating Cactus Basket blocks and Uneven Nine Patch blocks. Add the E triangles. When you are satisfied with the arrangement, join the E's and blocks into rows. Press the seam allowances toward the Uneven Nine-Patch blocks and the E's. Matching centers, ends, and seams, join the rows. Press the seam allowances open.

Cut the gray bird print F's in half diagonally once to make 2 half-square triangles. Repeat. Sew these triangles to the corners of the quilt center. Press.

Trim the quilt center to measure exactly  $45\frac{3}{4}$ " x  $45\frac{3}{4}$ " square.



## Adding the borders using partial seams

Right sides together, align the end of a white print border strip with the upper right corner of the quilt center. Join the border strip to the quilt center, stopping the stitching about 6" away from the edge of the quilt (Fig. 2). The end of the border will extend past the edge of the quilt.

Working counterclockwise, match centers and ends and add the remaining borders to the top, left side, and bottom of the quilt. Finally, complete the seam of the right side border (Fig. 3). Press the borders away from the quilt center.

In the same manner, add the gray sprig print borders to the quilt. Press. Your quilt top should measure  $65\frac{3}{4}$ " x  $65\frac{3}{4}$ ".

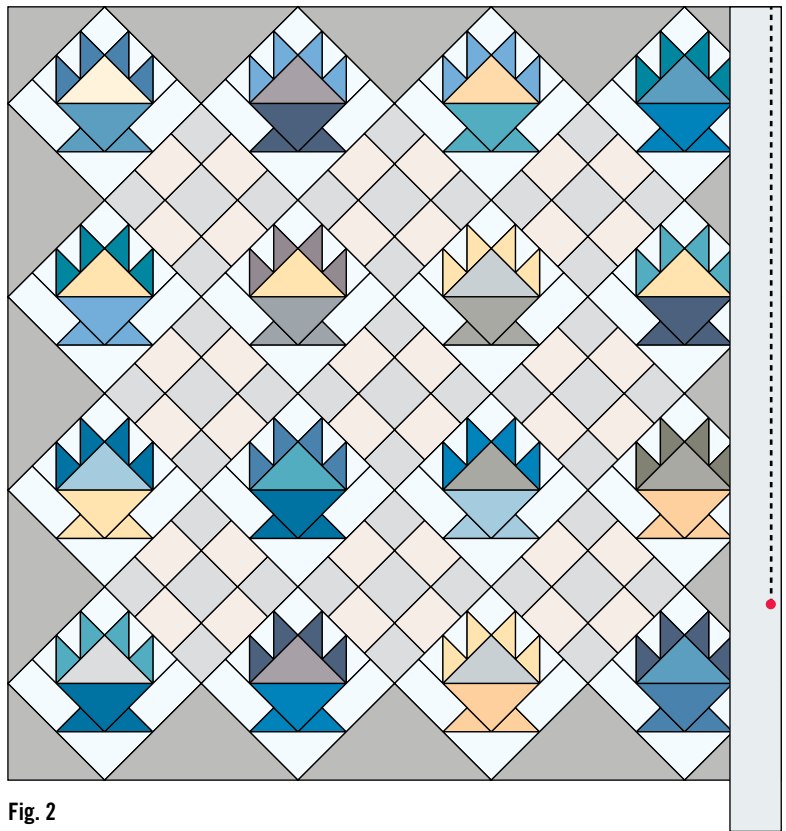

Fig. 2

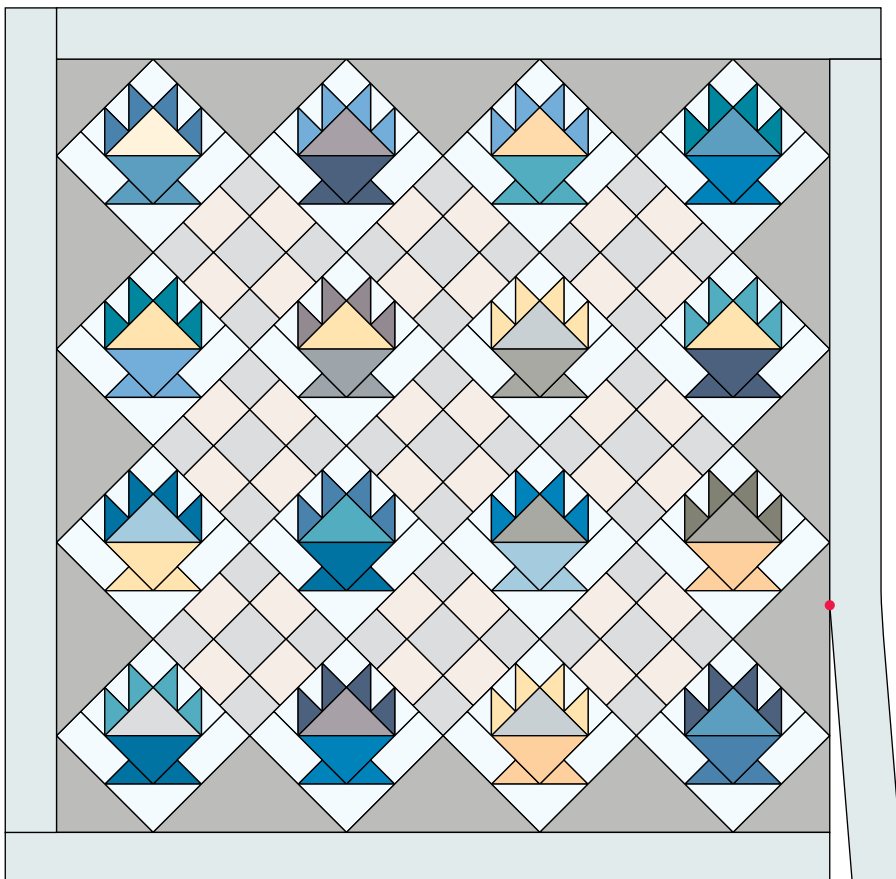
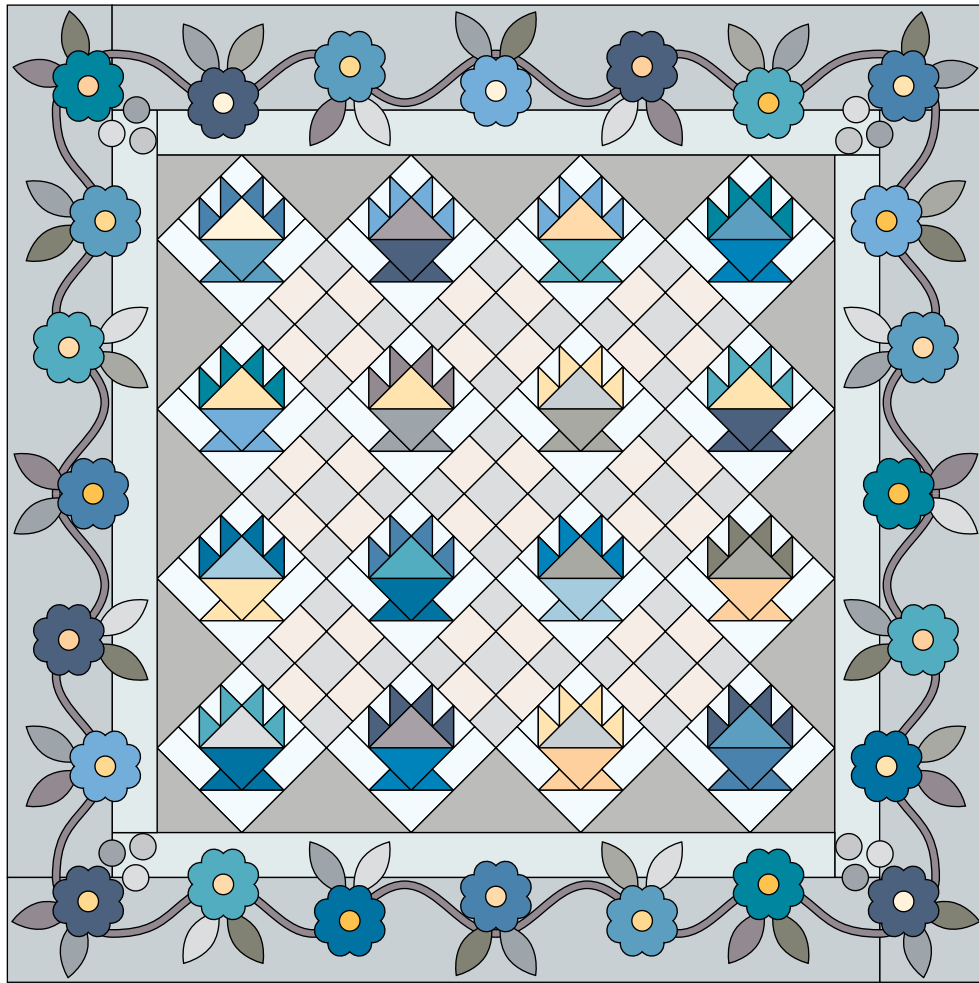

Fig. 3



**Quilt Assembly and Applique Placement**

## Appliquing the borders

Print the leaf and flower applique pattern, the circle, and the 3 vine placement pattern pages. Tape the vine placement pattern pages together, matching the dashed lines.

Use a light box or a light source behind the pattern if necessary. Center the pattern under the upper left side of the top border and trace the vine. Flip the pattern and trace the vine on the right side of the top border. Repeat for all borders.

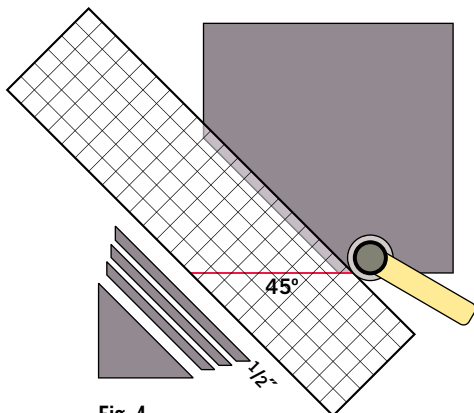

**Fig. 4**

Follow the manufacturer's instructions for your chosen fusible web. Prepare the 13" x 13" square of white floret/gray print for fusible applique. Referring to Fig. 4, cut the prepared fabric into  $\frac{1}{2}$ " bias strips. Join the strips end to end until the long strip measures 280".

On your ironing board, arrange the prepared vine along the marked placement line. Place the ends of the vine where they will be covered by a flower. Fuse the vine in place.

Using thread that matches the vine and a small blanket stitch, applique the vine to the borders by machine.

Prepare the remaining blue and aqua  $\frac{7}{8}$ " strips and remaining yellow and gray fabrics for fusible applique. Cut 24 flowers from the blue and aqua strips. Cut 48 leaves and 12 circles from gray. From yellow, cut 24 flower centers. Referring to the applique placement diagram, arrange the prepared flowers, leaves, and circles along the vine. Fuse in place. Applique the patches to the borders with matching thread and a small blanket stitch. Press the quilt top.

## Finishing the quilt

Layer and baste the backing, batting, and quilt top. Quilt as Angela did, or as desired.

Make the flange. Join the 1" flange strips end to end with diagonal seams. Trim excess fabric and press the seam allowances open. Measure across the quilt center and cut the long strip you just made into 4 strips this length.

Fold a strip in half lengthwise, wrong sides together, and press to make a flange. Matching centers and ends, align the raw edges of the flange with the top edge of the quilt. Baste close to the quilt's edge. Repeat for the bottom and then the sides of the quilt.

Join the binding strips end to end with diagonal seams, trim excess fabric, and press the seam allowances open. Fold the binding in half lengthwise, wrong sides together, and press to make a firm fold. Align the raw edges of the quilt top and the binding and sew the binding to the quilt. The flange will show  $\frac{1}{4}$ " beyond the binding. Turn the binding to the backing and whipstitch to finish the quilt.

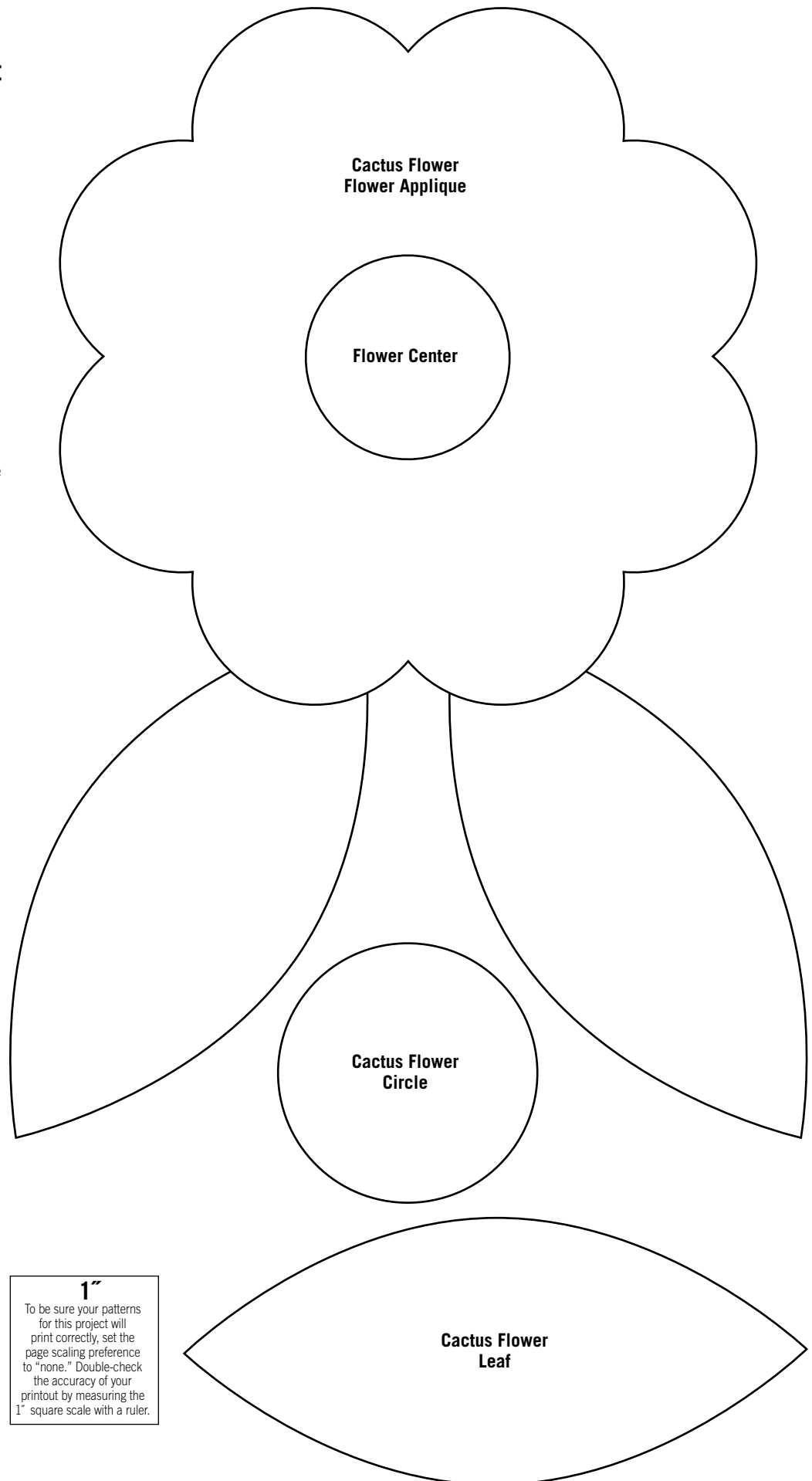



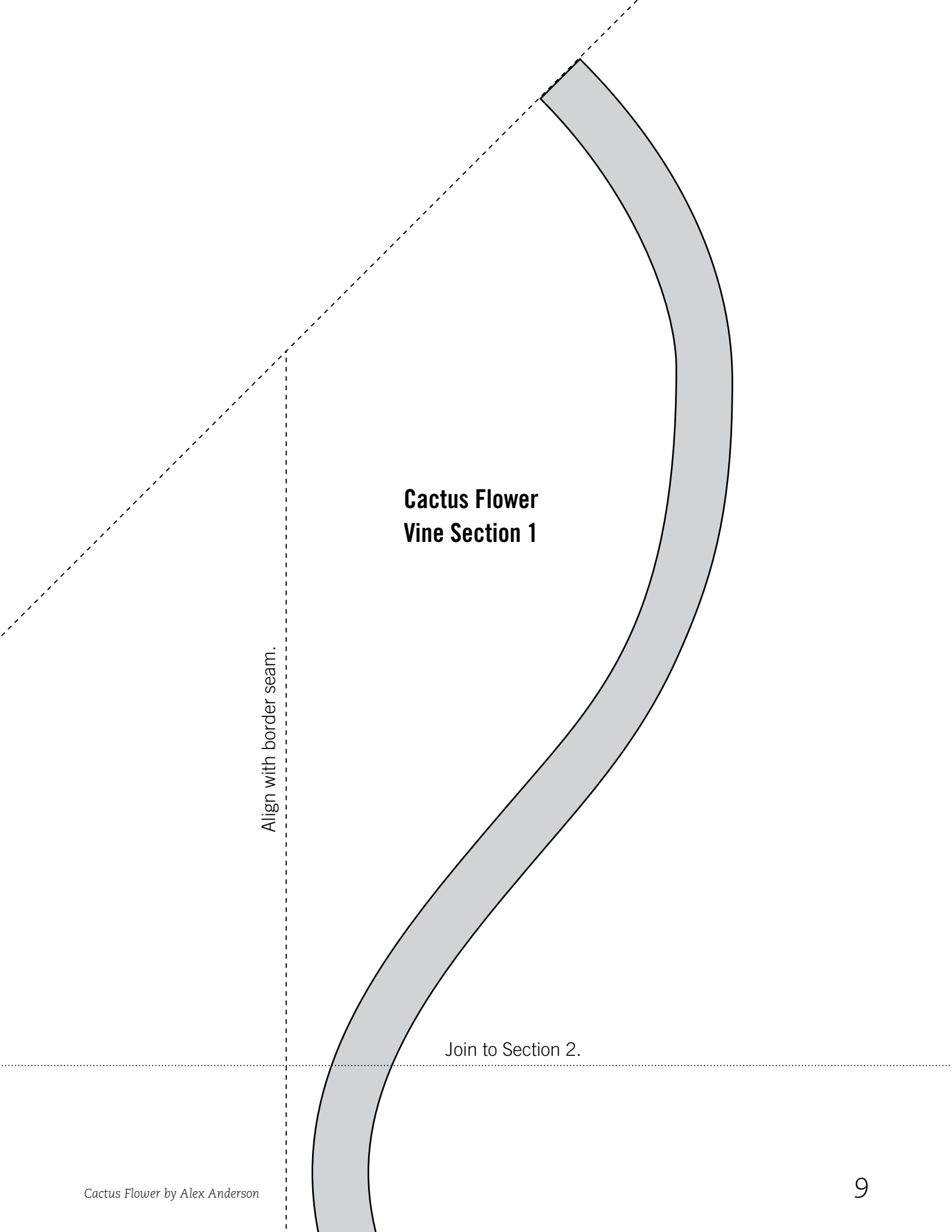

**Cactus Flower  
Vine Section 1**

Align with border seam.

Join to Section 2.

Join to Section 1.

Align with border seam.

**Cactus Flower  
Vine Section 2**

Join to Section 3.

Join to Section 2.

Align with border seam.

**Cactus Flower  
Vine Section 3**

Border Center