

NOVA BLAZE

A Foundation Paper Piecing 12" x 12" Block

hobbsDESIGNS,LLC



Fabric Requirements—Amounts may vary depending on technique and personal preference.

MODA BELLA SOLIDS	SYMBOL	AMOUNT
Super White (9900-436)		11" x 18"
Afternoon (9900-318)		8" x 8"
Cherry (9900-230)		8" x 8"
Melon (9900-295)		8" x 8"
Summer House Lime (9900-173)		8" x 8"
Seafoam (9900-191)		8" x 8"
Nautical Blue (9900-236)		9" x 9"

www.hobbsdesigns.com

HobbsDesignsLLC hobbsdesigns

For bonus content/tutorials, check out:
www.urbanloonstudios.com

© 2023 Hobbs Designs, LLC. All rights reserved.

Sold for individual and home use only and not for commercial or manufacturing purposes. No part of this pattern may be reproduced in any form without the written consent of the author.

Making the Nova Blaze Block

1. Piece all templates using the **Basic Paper Piecing Instructions** (included in these pages).
2. Join the template pieces using the diagrams below as a guide. With right sides together, place a straight pin through the points on the corners on both ends. Use pins or fabric clips along the seam as necessary to match critical seam alignments. If the seam alignment is critical, baste those areas to ensure that your seams align before your final stitching.
3. After joining two template pieces, ensure that they are properly aligned. Remove the paper from the **seam allowance only**, before adding the next template.
4. Remove the paper backing after all piecing has been completed.

NOTE: The template side shown in all piecing and assembly diagrams is a mirror image of the finished side of your block.

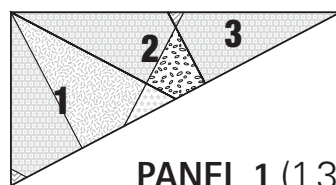

PANEL 1 (1.3)
1 + 2 + 3 = (1.3)

PANEL 3 (9.11)

9 + 10 + 11 = (9.11)

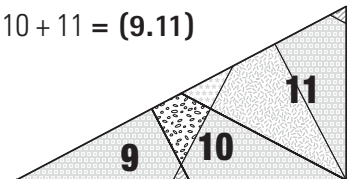

PANEL 2 (4.8)

4 + 5 + 6
7 + 8
(4.6) + (7.8) = (4.8)

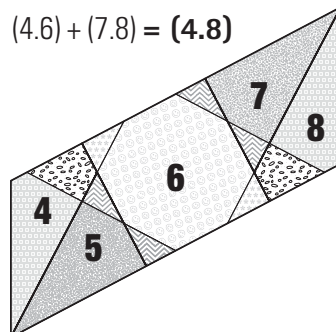

FULL BLOCK ASSEMBLY

Panel 1 (1.3) + Panel 2 (4.8) + Panel 3 (9.11)

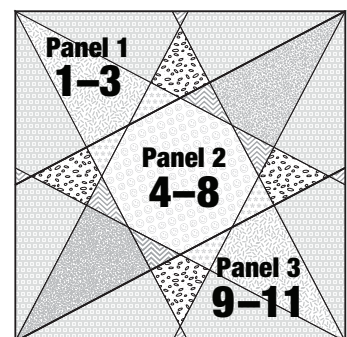



Permission to print or copy templates and instructions for personal use is granted.

*NOTE: Diagrams print at 100% using pages 7-12.







DESIGN N STITCH

with Quilters Select

FABRIC CHOICES—Attach swatches of your selected fabrics below the appropriate icon.

						
attach fabric swatch here	attach fabric swatch here	attach fabric swatch here	attach fabric swatch here	attach fabric swatch here	attach fabric swatch here	attach fabric swatch here

FABRIC CARDS—These cards can be cut apart and pinned/clipped to your fabric to help distinguish between colors.

						
---	---	---	---	--	---	---

CHECK THE SCALE OF YOUR TEMPLATES

Prior to printing/copying the templates, print/copy this page. Measure this scale to ensure your copies will be duplicated at 100%.

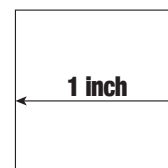
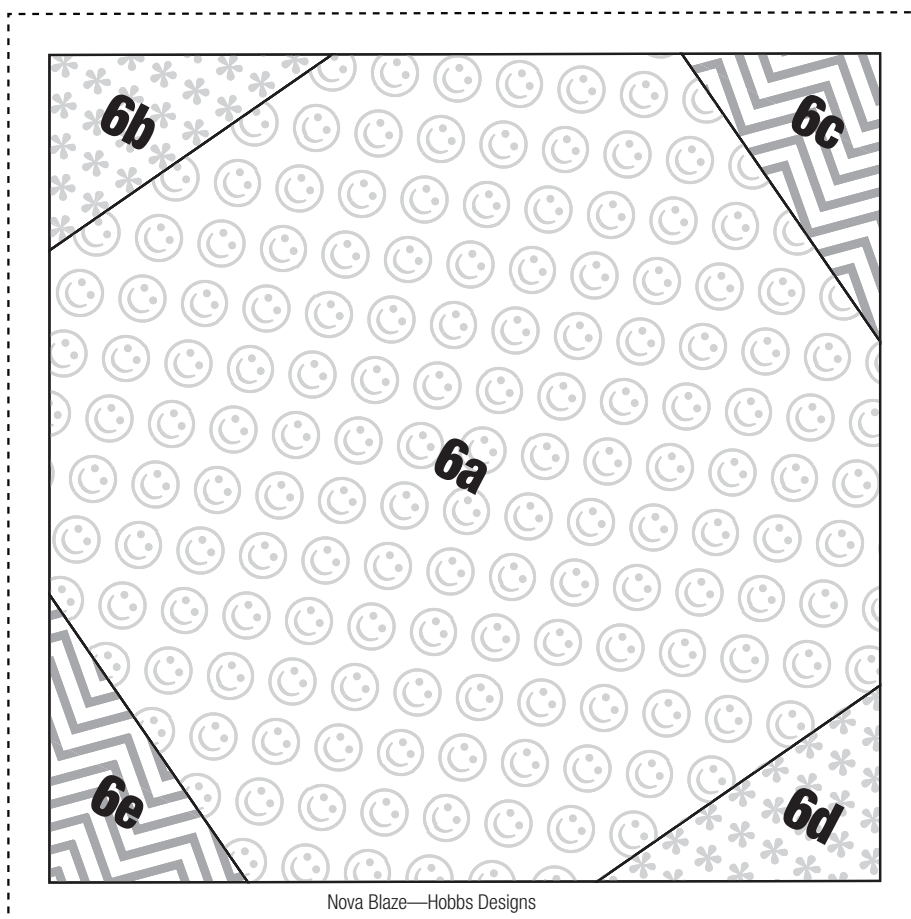

DESIGN N STITCH

with Quilters Select

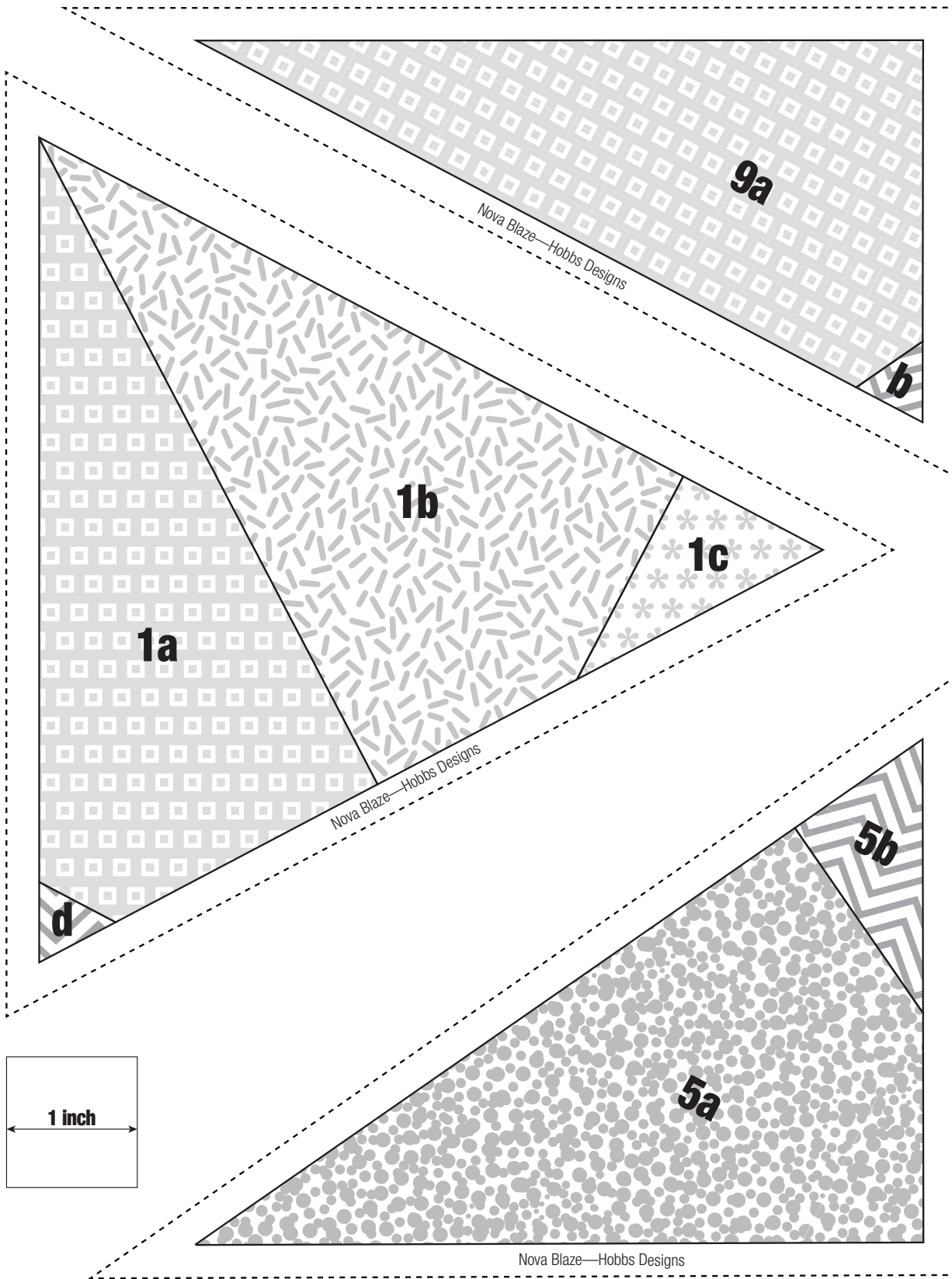

DESIGN N STITCH

with Quilters Select

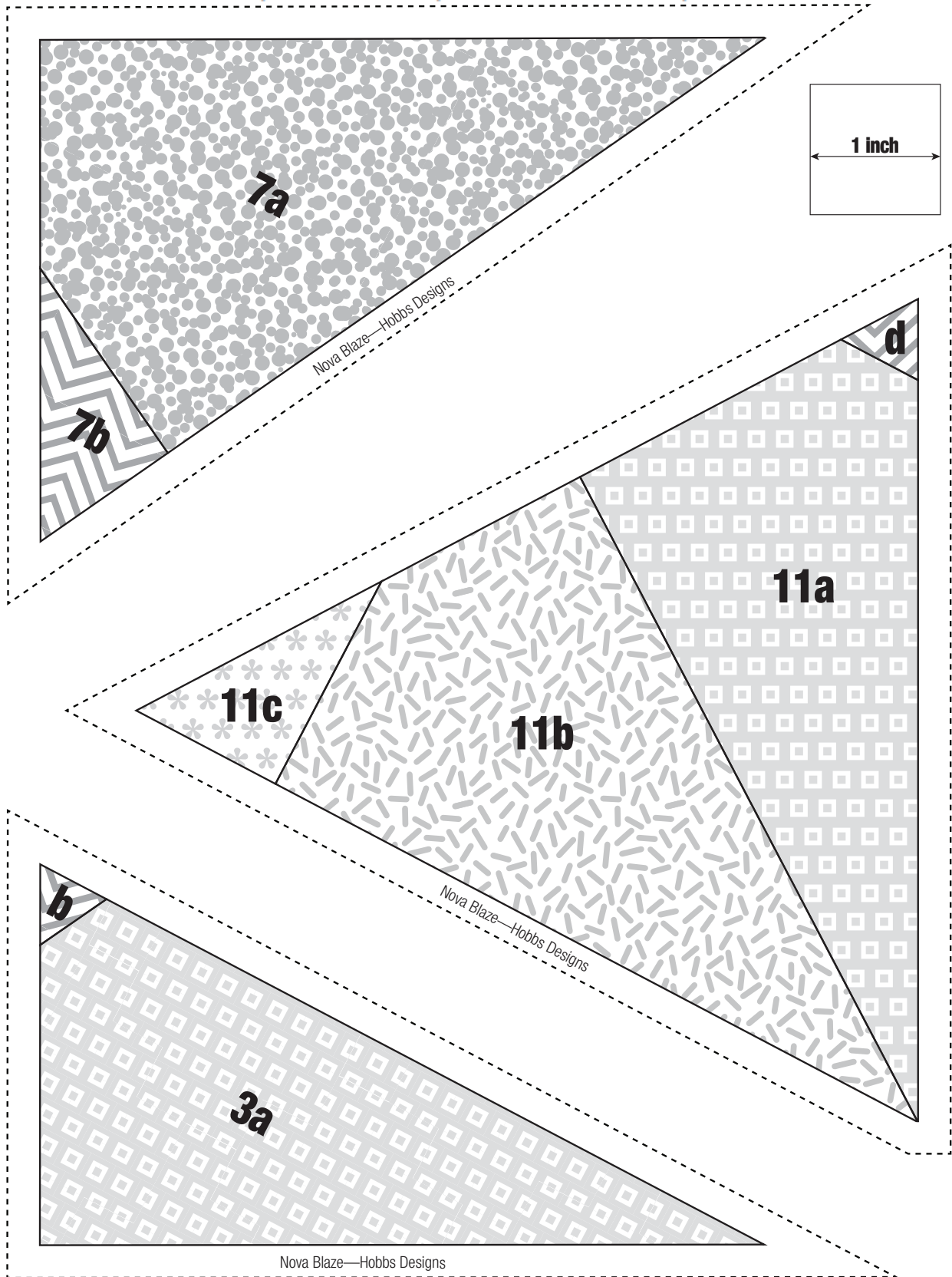

DESIGN N STITCH

with Quilters Select

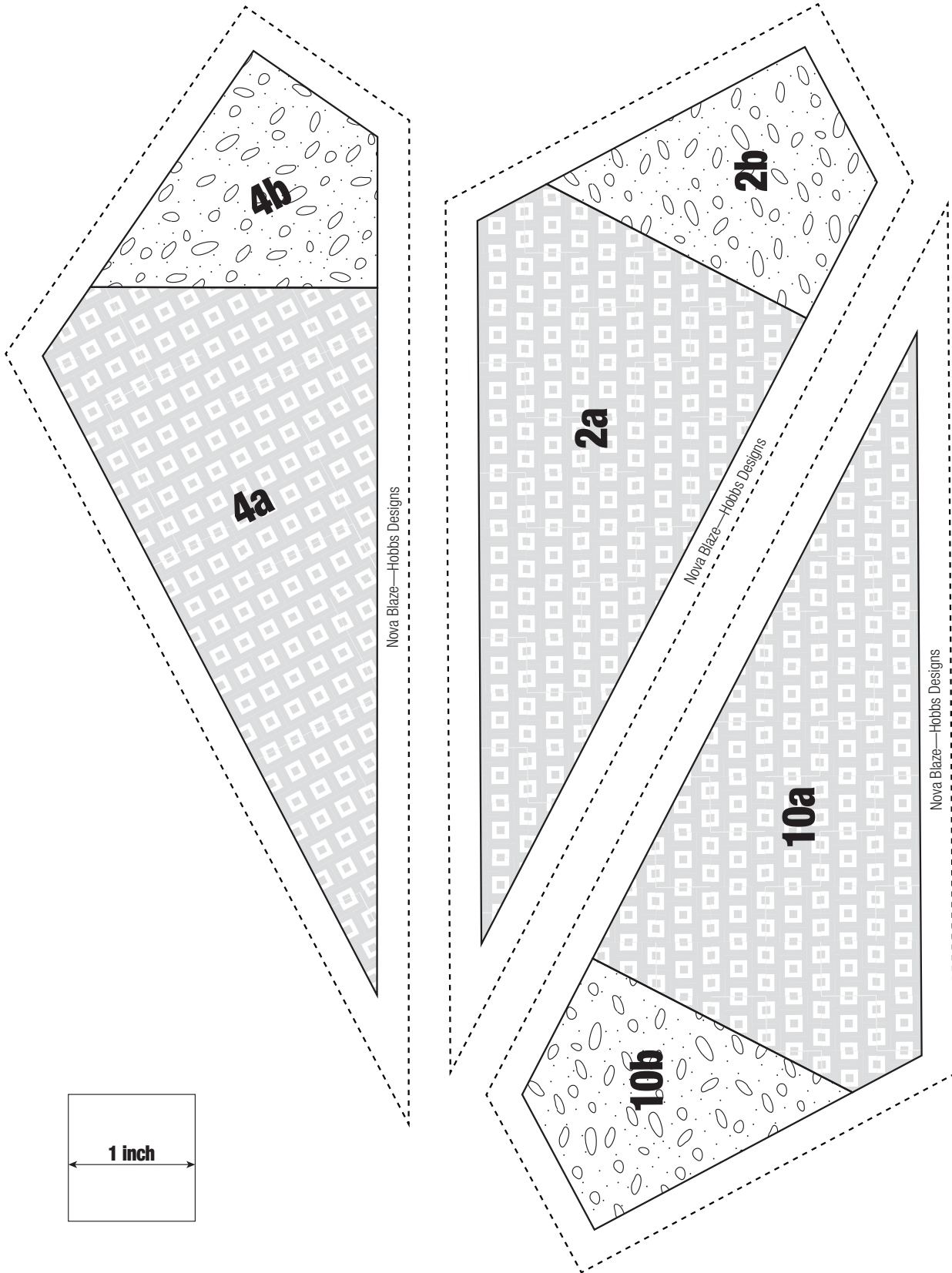

DESIGN N STITCH

with Quilters Select

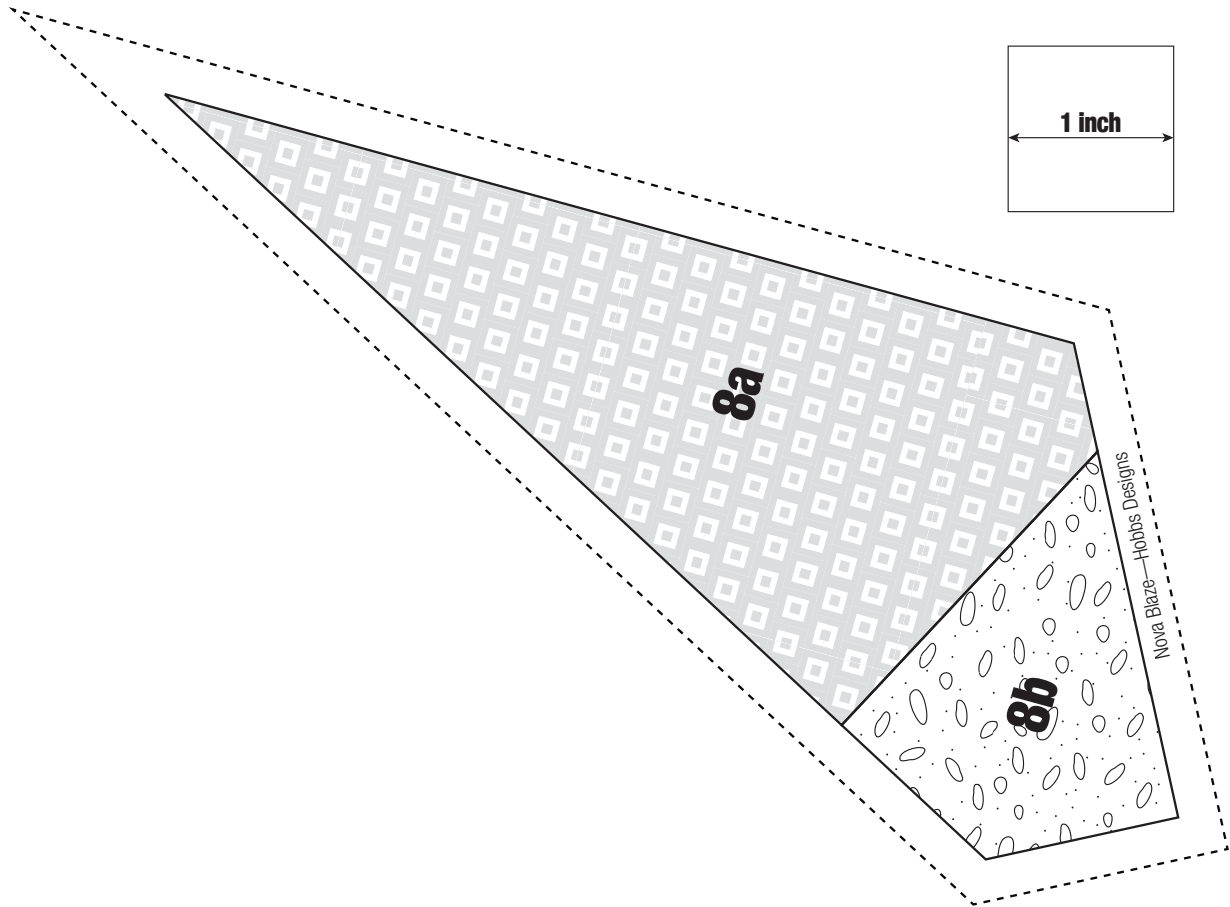





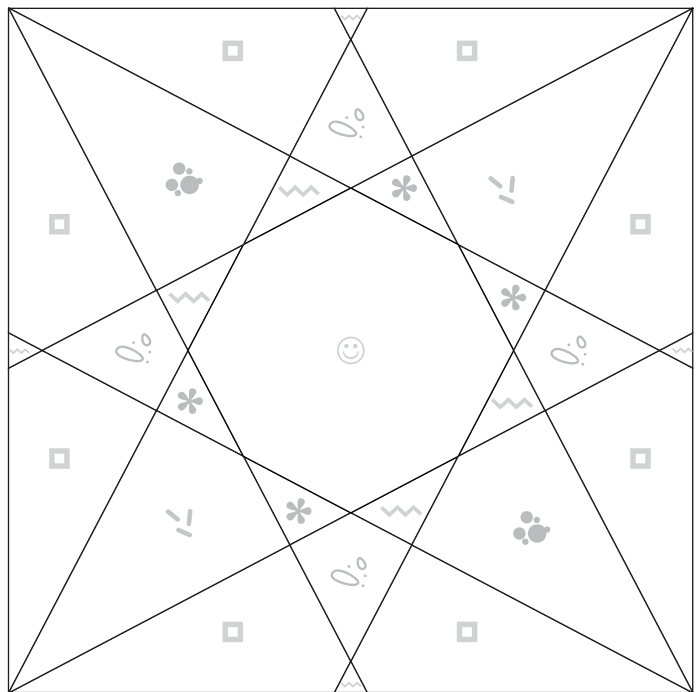

OPTIONAL COLOR PALETTE

This block can be copied and colored if you'd like to explore other palette options.









NOTE: The diagrams on pages 7-12 print at 100% of size.
Make sure your DEFAULT print setting is not set "FIT TO PAGE".

FABRIC CHOICES—Attach swatches of your selected fabrics below the appropriate icon.

						
attach fabric swatch here	attach fabric swatch here	attach fabric swatch here	attach fabric swatch here	attach fabric swatch here	attach fabric swatch here	attach fabric swatch here

FABRIC CARDS—These cards can be cut apart and pinned/clipped to your fabric to help distinguish between colors.

						
---	---	---	---	--	---	---

CHECK THE SCALE OF YOUR TEMPLATES

Prior to printing/copying the templates, print/copy this page.
Measure this scale to ensure your copies will be duplicated at 100%.

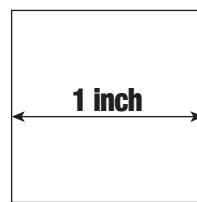
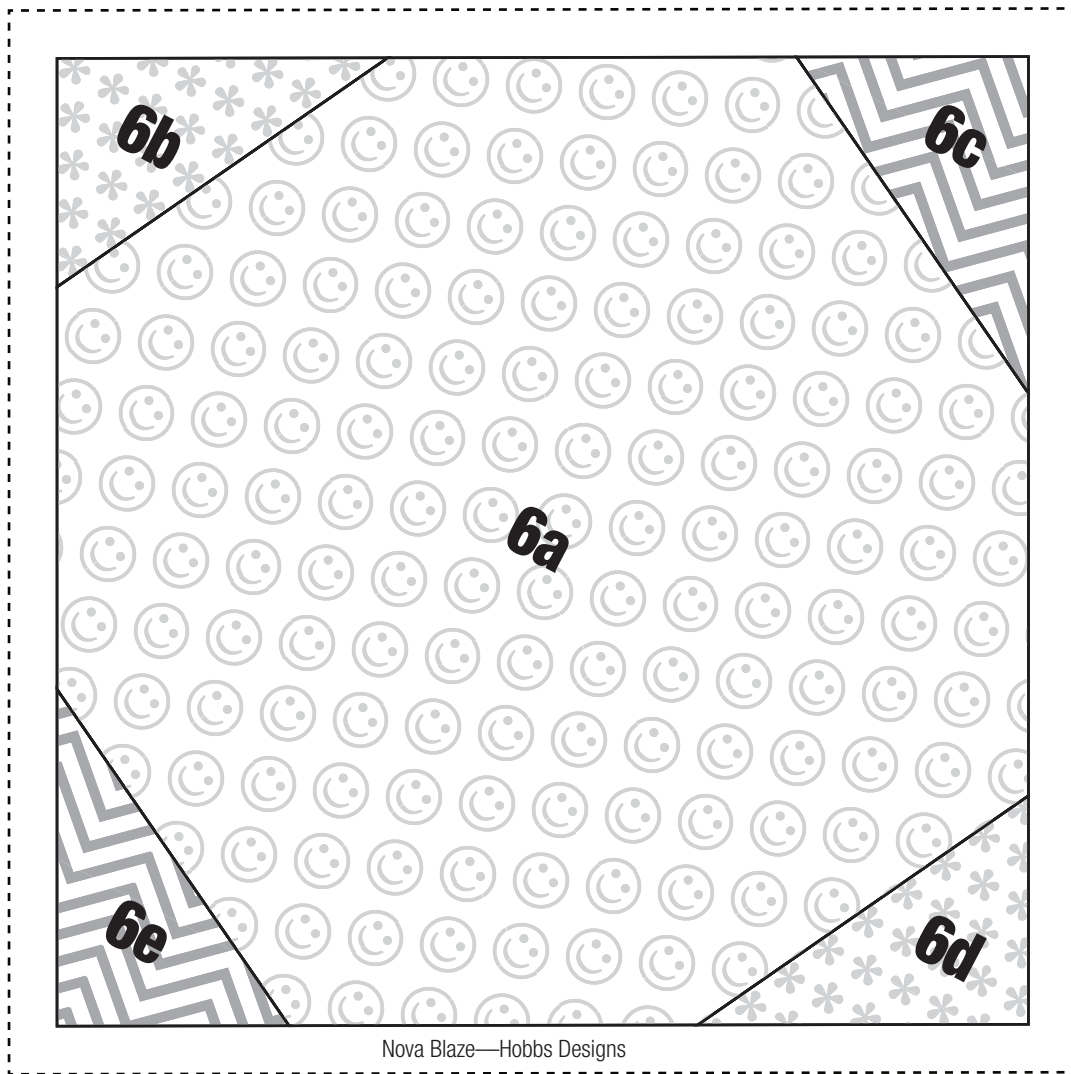

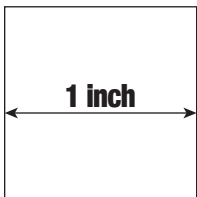
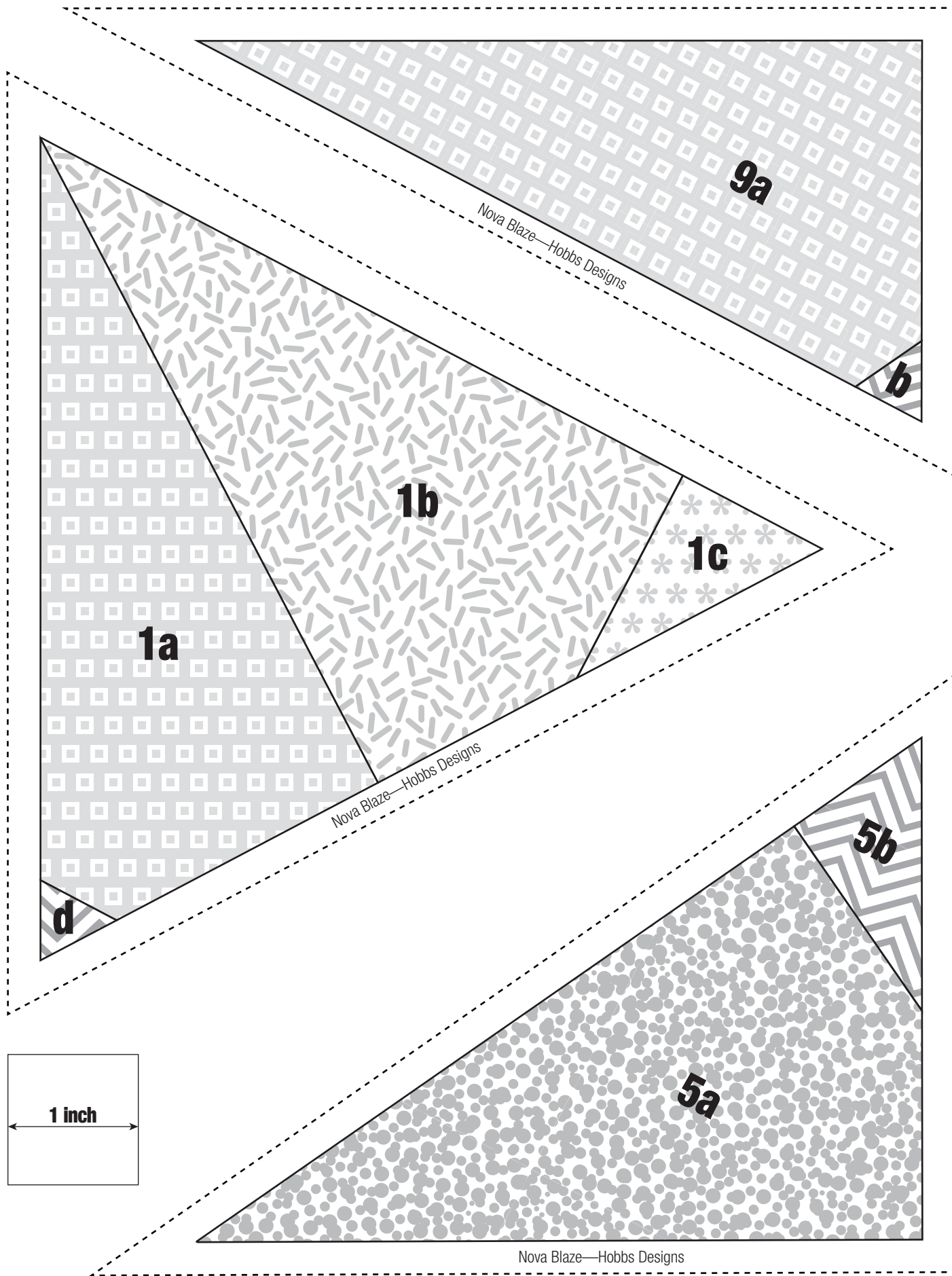

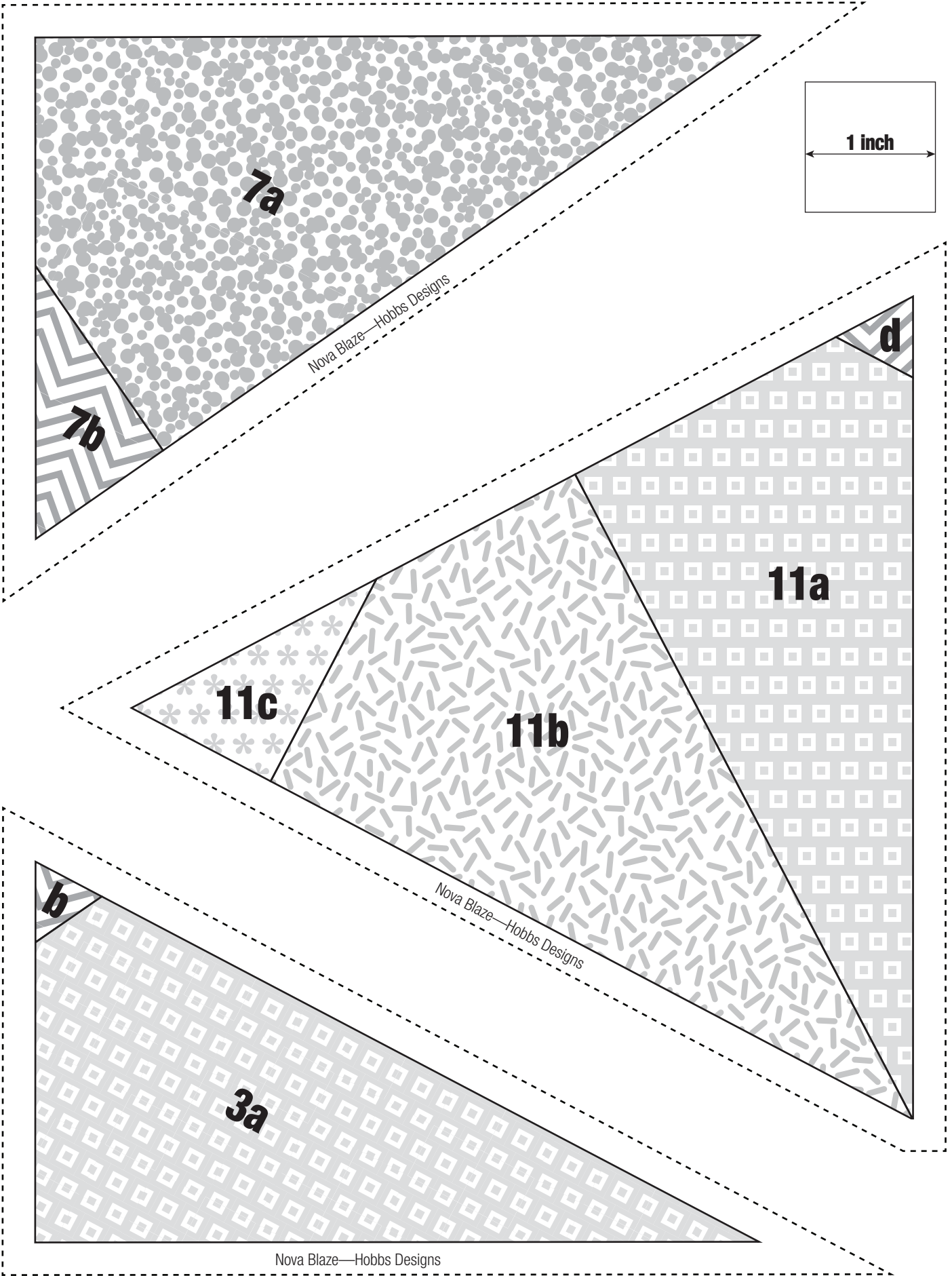

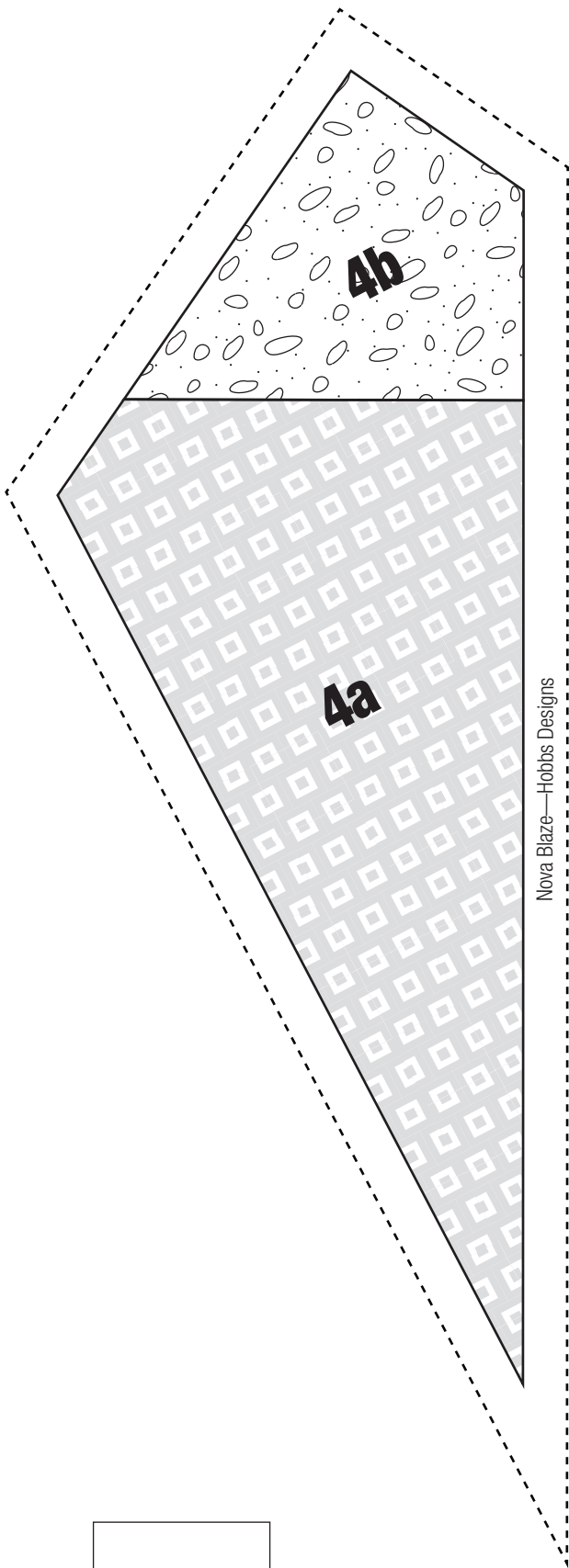

Nova Blaze—Hobbs Designs

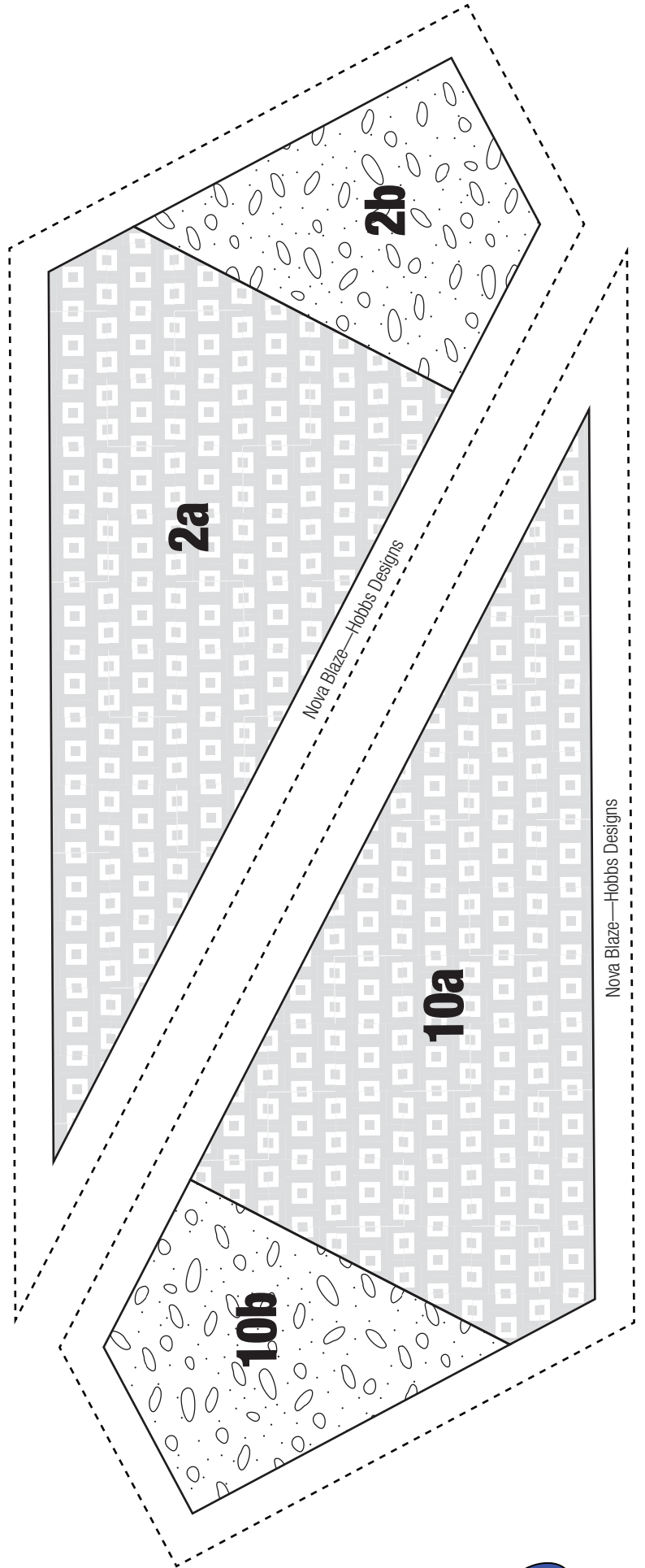
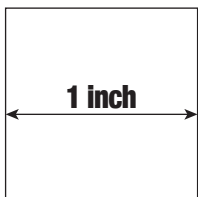

Nova Blaze—Hobbs Designs

Nova Blaze—Hobbs Designs

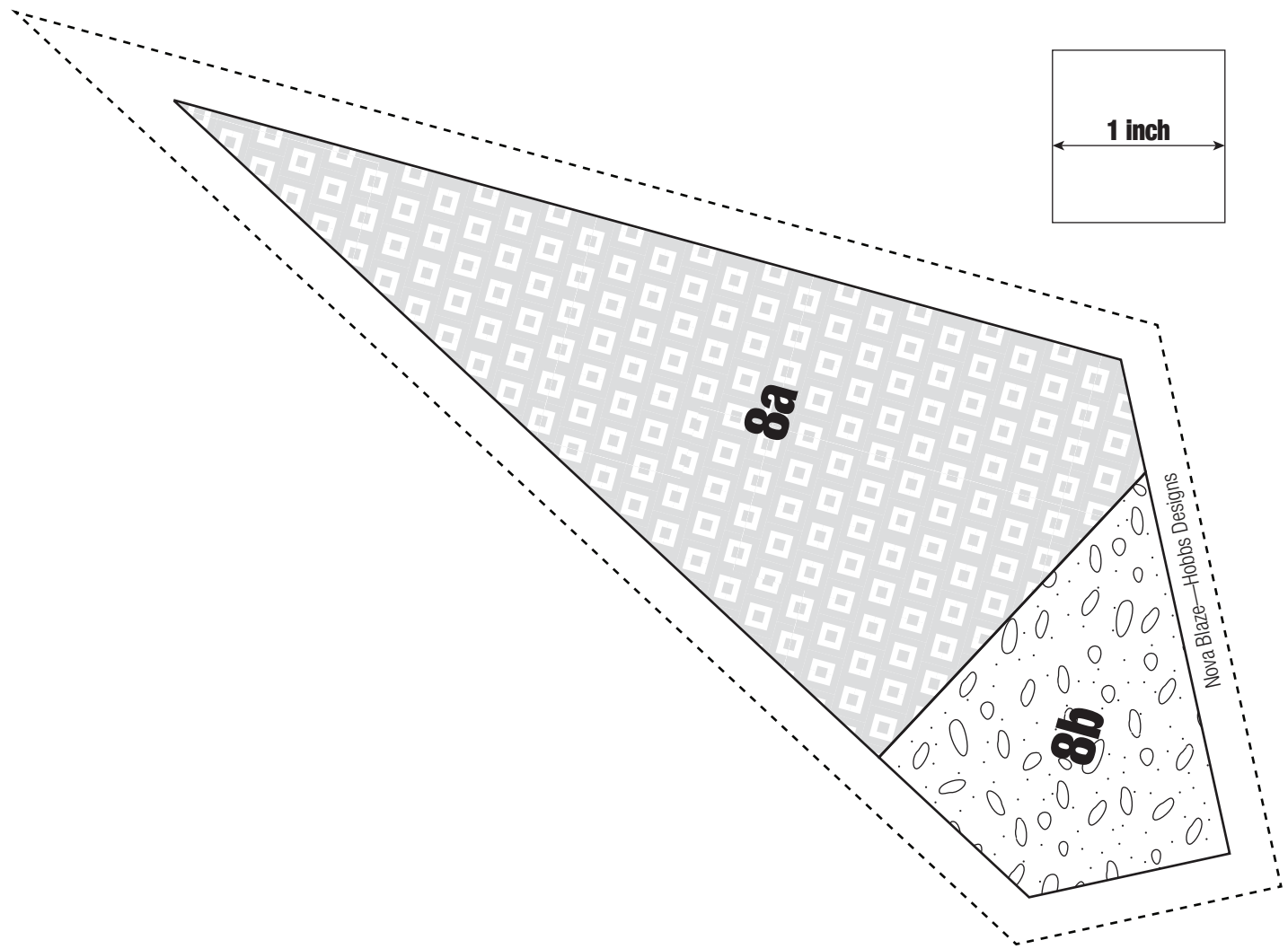

OPTIONAL COLOR PALETTE

This block can be copied and colored if you'd like to explore other palette options.

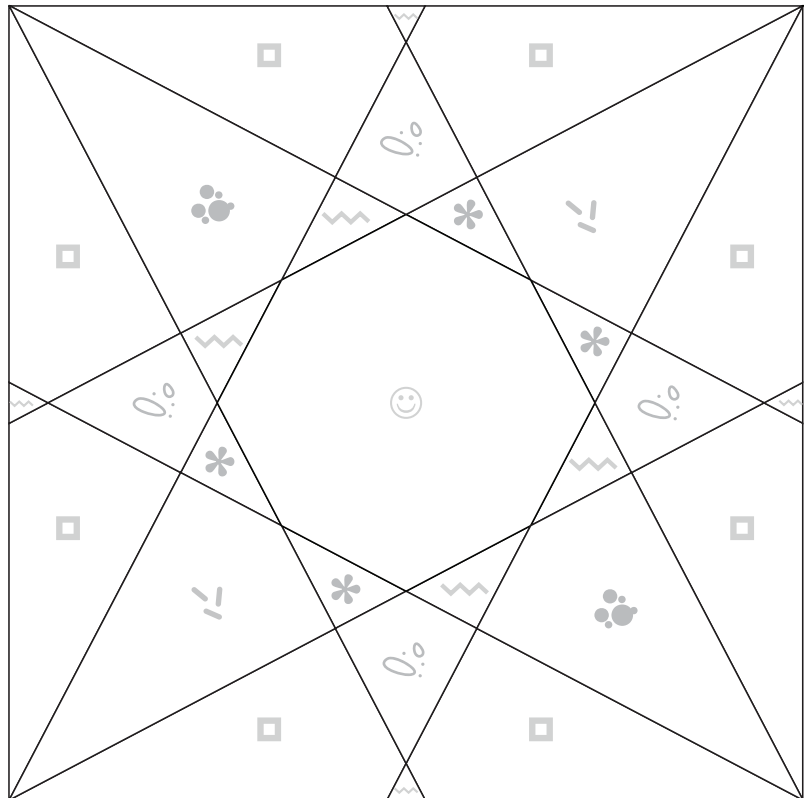

DESIGN N STITCH

with Quilters Select

BASIC PAPER PIECING INSTRUCTIONS

STEP 1: Fold the template on the stitching line between pieces **a** and **b** (Figure 1). Unfold the template.

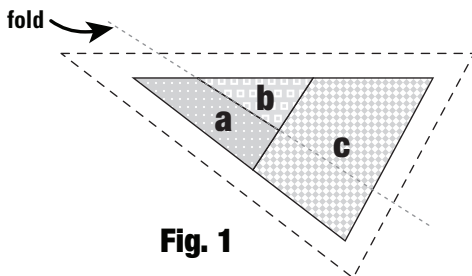

Fig. 1

STEP 2: Using a piece of fabric large enough to cover piece **a** and the seam allowance around it, place the reverse side of the fabric to the back of the foundation template. Using a piece of fabric large enough to cover piece **b**, place its right sides together with fabric **a** (Figure 2).

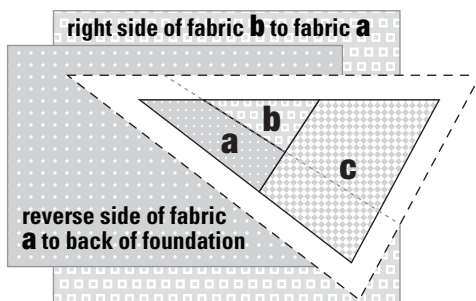

Fig. 2

To ensure that your piece **b** fabric is in the correct position, align it while the template is folded. At the least, it should cover the area shown when folded (Figure 3).

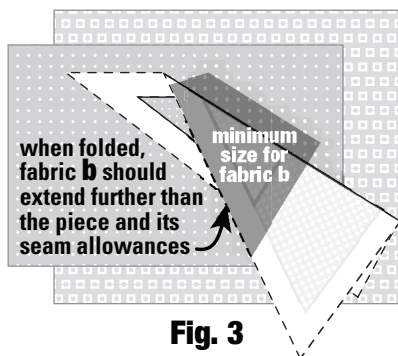

Fig. 3

STEP 3: With the template folded on the line, trim the seam allowance 1/4 inch from the folded edge of the template (Figure 4).

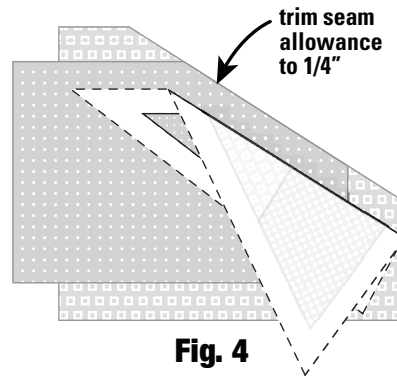

Fig. 4

STEP 4: Carefully pick up the fabric and template set and move to your machine. Unfold the template and stitch the line between **a** and **b**. Start sewing 1/4 inch before the line and stitch 1/4 inch beyond the line (Figure 5).

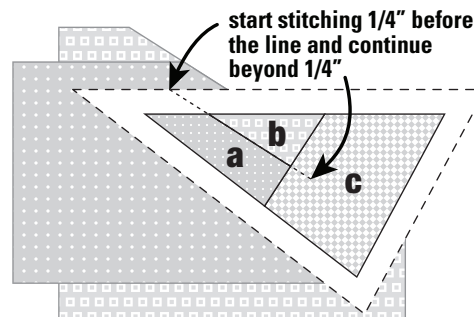

Fig. 5

STEP 5: Fold fabric **b** back into position and press the seam.

STEP 6: Gently tear away foundation from the extra stitching in piece **c** to the line between pieces **b** and **c**.

STEP 7: Repeat steps 1 through 7 for each lettered piece working sequentially through the alphabet (e.g., b/c, c/d, d/e).

STEP 8: Once the piece is completed, trim to the seam allowance.

Repeat for each template piece.